



C-SPLASH 2

POWERED BY CHROMACORE®



Color Kinetics® C-Splash 2 is the submersible member of the bColor Series family of fixtures. It is designed to operate in underwater locations up to fifteen feet deep, including water treated with bromine or chlorine. C-Splash 2 is perfect for fountains and theme park applications.

Note: C-Splash 2 is designed for underwater use or non-submersible applications, but should NOT be used in human-occupied underwater locations, such as pools and spas.

The soft-focus lens produces a soft-edge 22° beam of light, while the clear lens offers a 10° beam angle for extended light projection. C-Splash 2 can be controlled by a Color Kinetics controller or a third-party controller. Each fixture comes pre-addressed to light number one. Simple effects, such as fixed color and color wash, require no additional addressing. Other effects across multiple lights, including chasing Rainbow or Color Sweep, require further addressing using one of the following Color Kinetics addressing tools: Serialized Addressing Software (SAS) or Zapi.

C-Splash 2 comes with a unified power and data cable to minimize wiring. For maximum ease of installation, operation, and safety, Color Kinetics recommends using this fixture with the PDS-150e power/data supply or the PDS-60 24V power/data supply.

The C-Splash 2 fixture consists of a cast brass housing and yoke with silicon bronze adjusting hardware, and is bronze in color. It also comes equipped with a tempered soft focus glass diffuser or a clear tempered glass lens.

For protection from damage due to excessive temperature, C-Splash 2 has been designed with a temperature monitoring feature. If operating temperatures rise beyond what is permissible, C-Splash 2 operation is interrupted, causing the lights to turn dull red. After identifying and correcting the thermal problem, simply power cycle the fixture to return it to normal operation.

C-SPLASH 2 SPECIFICATIONS

COLOR RANGE	16.7 million (24bit) additive RGB colors; continuously variable intensity output range
SOURCE	High intensity power light emitting diodes (LEDs)
BEAM ANGLE	10° clear lens, 22° ground lens
HOUSING	Cast brass
CONNECTORS	Unified power and data cable
PROTECTION RATING	IP68
LISTINGS	UL/cUL, CE

COMMUNICATION SPECIFICATIONS

DATA INTERFACE CONTROL	Color Kinetics data interface system Color Kinetics full line of controllers or other DMX512 (RS485) compatible when using Color Kinetics power/data supply
-------------------------------	--

ELECTRICAL SPECIFICATIONS

VOLTAGE REQUIREMENT	24VDC
POWER CONSUMPTION	Maximum: 25 Watts at full intensity (full RGB)
POWER SUPPLY	PDS-150e (ITEM# 109-000008-01) - Maximum of 6 fixtures/supply PDS-60 24V (ITEM# 109-000017-00/01/02) - Maximum of 2 fixtures/supply

ENVIRONMENTAL SPECIFICATIONS

TEMPERATURE RANGE	-40°F to 122°F (-40°C to 50°C) operating temperature -4°F to 122°F (-20°C to 50°C) starting temperature
SUBMERSION DEPTH	Up to 15 feet (5 meters) maximum

LED SOURCE LIFE

In traditional lamp sources, lifetime is defined as the point at which 50% of the lamps fail. This is also termed Mean Time Between Failure [MTBF]. LEDs are semiconductor devices and have a much longer MTBF than conventional sources. However, MTBF is not the only consideration in determining useful life. Color Kinetics uses the concept of useful light output for rating source lifetimes. Like traditional sources, LED output degrades over time (lumen depreciation) and this is the metric for SSL lifetime.

LED lumen depreciation is affected by numerous environmental conditions such as ambient temperature, humidity and ventilation. Lumen depreciation is also affected by means of control, thermal management, current levels, and a host of other electrical design considerations. Color Kinetics systems are expertly engineered to optimize LED life when used under normal operating conditions. Lumen depreciation information is based on LED manufacturers' source life data as well as other third party testing. Low temperatures and controlled effects have a beneficial effect on lumen depreciation. Overall system lifetime could vary substantially based on usage and the environment in which the system is installed.

Temperature and effects will affect lifetime. Color Kinetics rates product lifetime using lumen depreciation to 50% of original light output. When the fixture is running at room temperature using a color wash effect, the range of lifetime is in the range of 80,000-100,000 hours. This is LED manufacturers' test data. High output is defined as any LED device that is 1/2 watt or above. For more detailed information on source life, please see www.colorkinetics.com/lifetime.

OPTIBIN®

There are inherent variations in the fabrication processes of all semiconductor materials. For LEDs, this variance results in differences in the color and intensity of light output as well as electrical characteristics. Due to these differences, LED manufacturers sort production into "bins," but insuring the availability of a single bin is very difficult. To minimize this issue and achieve optimal color consistency in its products, Color Kinetics has developed and uses a proprietary technology called Optibin. Optibin is an advanced production binning optimization process that minimizes the effects of LED variance for the best possible output uniformity in the final product. Color Kinetics Optibin technology gives you the most consistent control of color and intensity from product to product.



ITEM# 116-000011-00 (Frosted Lens)
116-000011-01 (Clear Lens)

This product is protected by one or more of the following patents: U.S. Patent Nos. 6,016,038, 6,150,774 and other patents listed at <http://colorkinetics.com/patents/>. Other patents pending.

©2005-2006 Color Kinetics Incorporated. All rights reserved. Chromacore, Chromasic, Color Kinetics, the Color Kinetics logo, ColorBlast, ColorBlaze, ColorBurst, ColorCast, ColorPlay, ColorScape, Direct Light, iColor, iColor Cove, iPlayer, Optibin, Powercore, QuickPlay, Sauce, the Sauce logo, and SmartJuice are registered trademarks and DIMand, IntelliWhite, Video With Light, and Light Without Limits are trademarks of Color Kinetics Incorporated.

All other brand or product names are trademarks or registered trademarks of their respective owners.

BRO112 Rev 06

Specifications subject to change without notice. Refer to www.colorkinetics.com for the most recent data sheet versions.

COLOR KINETICS INCORPORATED • 10 MILK STREET, SUITE 1100 • BOSTON, MA 02108 • USA

TEL 888 FULL RGB • TEL 617 423 9999 • FAX 617 423 9998 • INFO@COLORKINETICS.COM • WWW.COLORKINETICS.COM

C-SPLASH 2 CLEAR LENS

PHOTOMETRIC PERFORMANCE

SOURCE SPECIFICATIONS

Optics: Clear tempered glass
 Source: 18 LEDs (6 Red, 6 Green, 6 Blue)
 Beam Angle: 10°
 Distribution: Symmetric direct illumination
 CCT: Adjustable 1,000K-10,000K
 CRI: Not measurable (CIE 13.3-1995)

ILLUMINANCE DISTRIBUTION

0.9 9.7	1.5 16.1	2.0 21.5	1.7 18.3	1.2 12.9	0.8 8.6	6.0'/2.0m
1.3 14.0	4.2 45.2	6.9 74.3	5.0 53.8	2.1 22.6	1.0 10.8	5.0'/1.5m
1.7 18.3	14.4 155.0	28.6 307.9	19.3 207.7	4.9 52.7	1.3 14.0	4.0'/1.2m
1.7 18.3	15.2 163.6	39.3 423.0	39.0 419.8	14.8 159.3	1.6 17.2	3.0'/1.0m
1.1 11.8	5.1 54.9	20.5 220.7	29.7 319.7	14.7 158.2	1.5 16.1	2.0'/0.6m
0.5 5.4	1.5 16.1	5.0 53.8	7.3 78.6	4.2 45.2	0.9 9.7	1.0'/0.3m
3.0'/1.0m		0'/0m				3.0'/1.0m

Units: Footcandles (top)/Lux (bottom)
 10.8 lux = 1 fc
 Measured on: All, reflectance model 80/50/20%
 Distance from surface: Bottom center of grid, 3' (1.0 m) from surface, light at a 45° angle off horizontal

CANDLE POWER DISTRIBUTION

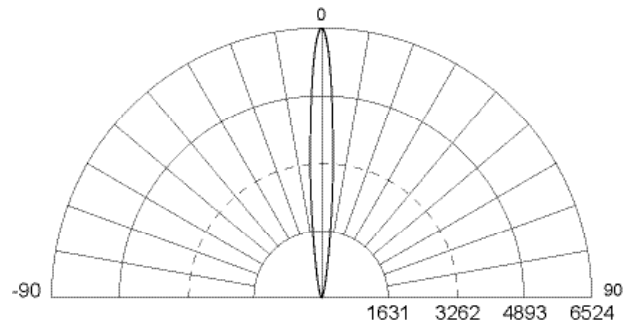

Measured on: White
 Beam center: 6524 cd
 Thin dashed line: Indicates 50% of peak
 Multipliers: 0.33 Red, 0.49 Green, 0.19 Blue

ILLUMINANCE

COLOR	3' 1m	6' 2m	9' 3m	15' 5m
WHITE	727.0 7825.4	181.0 1948.3	80.6 867.6	29.0 312.2
RED	239.8 2581.6	59.7 642.7	26.6 286.2	9.6 103.0
GREEN	358.0 3853.2	89.1 959.3	39.7 427.2	14.3 153.7
BLUE	138.4 1490.0	34.5 371.0	15.3 165.2	5.5 59.4

Measured in Footcandles (top)/Lux (bottom) on axis.
 Measured on: All, reflectance 0.

LIGHT OUTPUT

COLOR	TOTAL OUTPUT (lumens)	POWER (Watts)	EFFICACY (Lm/W)
WHITE	301	24.7	12.2
RED	99.3	8.4	11.8
GREEN	148.2	8.4	17.6
BLUE	57.3	8.4	6.8

C-SPLASH 2 GROUND LENS

PHOTOMETRIC PERFORMANCE

SOURCE SPECIFICATIONS

Optics: Tempered soft focus glass diffuser
 Source: 18 LEDs (6 Red, 6 Green, 6 Blue)
 Beam Angle: 22°
 Distribution: Symmetric direct illumination
 CCT: Adjustable 1,000K–10,000K
 CRI: Not measurable (CIE 13.3-1995)

ILLUMINANCE DISTRIBUTION

1.6 17.2	2.5 26.9	3.2 34.4	2.9 31.2	2.1 22.6	1.4 15.1	6.0'/2.0m
2.3 24.8	4.8 51.7	7.0 75.3	5.9 63.5	3.4 36.6	1.8 19.4	5.0'/1.5m
3.0 32.3	9.0 96.9	15.0 161.5	12.5 134.6	6.0 64.6	2.4 25.8	4.0'/1.2m
3.2 34.4	10.9 117.3	20.9 225.0	19.9 214.2	9.7 104.4	3.0 32.3	3.0'/1.0m
2.5 26.9	7.8 84.0	16.9 181.9	19.0 204.5	10.4 111.9	3.1 33.4	2.0'/0.6m
1.7 18.3	3.8 40.9	8.2 88.3	10.3 110.9	6.4 68.9	2.3 24.8	1.0'/0.3m
3.0'/1.0m		0'/0m		3.0'/1.0m		

Units: Footcandles (top)/Lux (bottom)
 10.8 lux = 1 fc
 Measured on: All, reflectance model 80/50/20%
 Distance from surface: Bottom center of grid, 3' (1.0 m) from surface, light at a 45° angle off horizontal

CANDLE POWER DISTRIBUTION

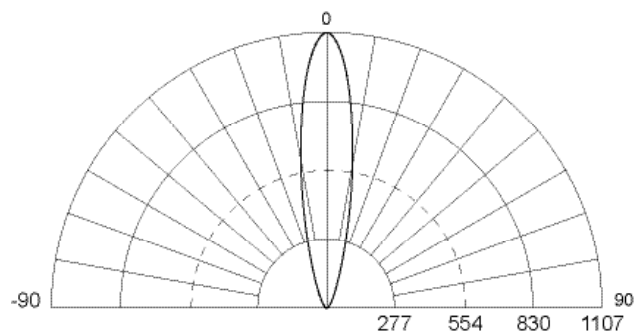

Measured on: White
 Beam center: 1107 cd
 Thin dashed line: Indicates 50% of peak
 Multipliers: 0.34 Red, 0.48 Green, 0.19 Blue

ILLUMINANCE

COLOR	3' 1m	6' 2m	9' 3m	15' 5m
WHITE	123.0 1324.0	30.8 331.5	13.7 147.5	4.9 52.7
RED	41.8 450.2	10.5 112.7	4.7 50.1	1.7 17.9
GREEN	59.0 635.5	14.8 159.1	6.6 70.8	2.4 25.3
BLUE	23.0 247.6	5.8 62.0	2.6 27.6	0.9 9.9

Measured in Footcandles (top)/Lux (bottom) on axis.
 Measured on: All, reflectance 0.

LIGHT OUTPUT

COLOR	TOTAL OUTPUT (lumens)	POWER (Watts)	EFFICACY (Lm/W)
WHITE	305	24.7	12.3
RED	103.7	8.4	12.3
GREEN	146.4	8.4	17.4
BLUE	57.0	8.4	6.8

C-SPLASH 2

PHYSICAL DIMENSIONS

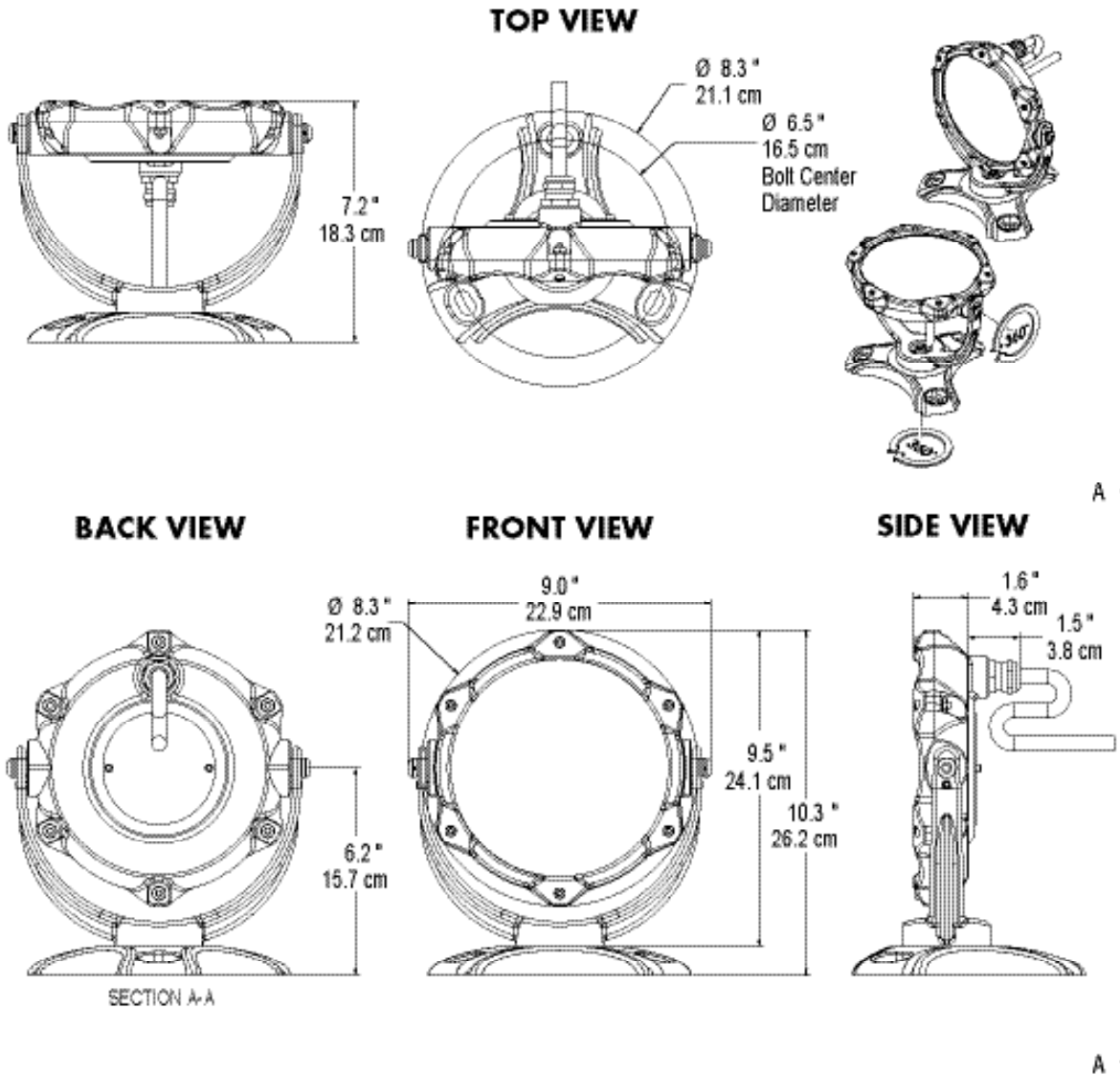

C-SPLASH 2 FIXTURE ITEM# 116-000011-00/01	
WEIGHT	22 lbs, 10 kg
DATA	Unified power/data input cable
POWER CONNECTOR	60' unterminated pigtail
POWER REQUIREMENTS	24VDC (25W)

C-SPLASH 2

WIRING DIAGRAM

