

# COLORBLAST 6

INSTALLATION GUIDE



COLOR KINETICS INCORPORATED  
10 MILK STREET, SUITE 1100  
BOSTON, MA 02108 USA  
TEL 888 FULL RGB  
TEL 617 423 9999  
FAX 617 423 9998  
INFO@COLORKINETICS.COM  
WWW.COLORKINETICS.COM

ITEM# 116-000001-00 (White)  
116-000001-01 (Black)  
116-000001-02 (Aluminum)

U.S. PATENTS 6,016,038, 6,150,774 AND 6,340,868  
EUROPEAN PATENT 1,016,062  
OTHER PATENTS PENDING

©2002 Color Kinetics Incorporated. All rights reserved. Chromacore, Color Kinetics, the Color Kinetics logo, ColorBlast, ColorBurst, ColorPlay, ColorScape, iColor, iColor Cove, iPlayer, QuickPlay, and Smartjuice are registered trademarks, and ColorBlaze, ColorCast and Optibin are trademarks of Color Kinetics Incorporated

PUB-000073-00 Rev. 02

Specifications subject to change without notice.

## Introduction

Welcome to a more colorful world brought to you by Color Kinetics and Chromacore®, our patented core technologies that generate and control millions of colors and a variety of lighting effects using a microprocessor to control LEDs. This guide contains important information about installing and operating your new ColorBlast® 6 safely.

Fig. 1

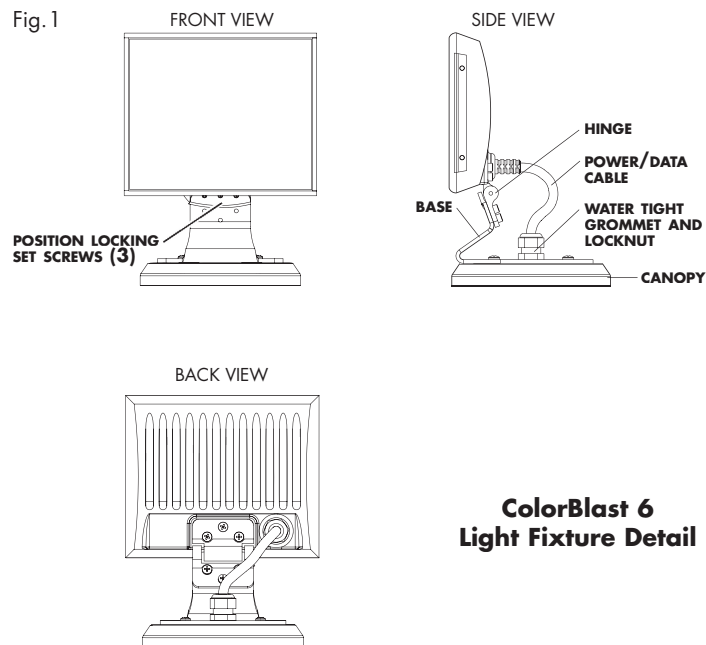

**ColorBlast 6  
Light Fixture Detail**

## Included in this box:

- ColorBlast 6 with base
- Canopy
- Water-tight grommet assembly
- 2- fastening screws for indoor installation
- Swivel bracket for indoor installation
- Allen wrench
- Warranty and Registration cards
- Installation Guide

## Additional items needed:

- 4" Electrical junction box (rated for your application) with 3.5" center to center distance for mounting locations.
- 24VDC Color Kinetics power/data supply - PDS-150e (Item# 109-000008-01)
- Controller - Color Kinetics or DMX compatible
- Light addressing tool: Color Kinetics Zapi (Item# 103-000005-00, US/103-000005-01, EU) or Serial Addressing Software (SAS) with iPlayer 2 or Smart Jack 3
- Adjustable wrench
- Torque wrench

## Scope of This User Guide

The goal of this user guide is to explain in an easily understood language the necessary steps to install ColorBlast 6 and assure peak performance. Its intended use is for reference only, by qualified professionals. This document should never be considered a substitute for any provisions of a regulation or state, local and/or national codes.

## Identification and Warnings of Safety Hazards

In accordance with ANSI MH29.1 the following system of identifying the severity of the hazards associated with the products is used:

**"DANGER"** Imminently hazardous situation which, if not avoided, will result in death or serious injury.

**"WARNING"** Potentially hazardous situation that, if not avoided, could result in death or serious injury.

**"CAUTION"** Potentially hazardous situation that, if not avoided, may result in minor or moderate injury or property damage.

**DANGER:** Ensure that main power supply is off before installing or wiring ColorBlast 6 and PDS-150e power supply. Failure to adhere to these instructions will result in death or serious injury.

**WARNING:** ColorBlast 6 and PDS-150e power supply must be installed by a qualified professional in accordance with NEC and relevant local codes. Failure to comply can result in death, serious injury, or property damage.

**WARNING:** Do not attempt to install or use ColorBlast 6 or PDS-150e until you read and understand the installation instructions and safety labels. Failure to adhere to these instructions could result in serious injury or property damage.

**CAUTION:** ColorBlast 6 has no serviceable parts. Do not attempt open the fixture. Doing so will result in property damage and void the warranty.

**CAUTION:** Do not modify, alter, or attempt to service the ColorBlast 6. Doing so will void the warranty.

**CAUTION:** Do not use sharp tools near or on the fixture lens. Doing so will result in property damage and void the warranty.

**CAUTION:** Do not hot swap. Ensure the power supply is off before connecting or disconnecting fixtures. Hot swapping will result in property damage and void the warranty

**NOTE:** The instructions and precautions set forth in this installation guide are not necessarily all-inclusive, all conceivable, or relevant to all applications as Color Kinetics cannot anticipate all conceivable or unique situations.

## Owner/User Responsibilities

It is the responsibility of the contractor, installer, purchaser, owner and user to install, maintain, and operate ColorBlast 12 in such a manner as to comply with all state, local, and national laws, ordinances, regulations, and the American National Standard Institute Safety Code.

## Plan the Installation

The nature of a ColorBlast 6 installation requires planning to ensure a timely, successful installation with minimal complications and down time.

## Planning suggestions

When planning a ColorBlast 6 installation, Color Kinetics suggests doing the following:

- Consult a Electrical Inspector to approve all wiring plans.
- Refer to local and state codes for installation compliance.
- Create a Mapping Grid. Use this grid to record serial numbers for easy reference and addressing.
- Create a Layout Plan drawing, per Lighting Designer or Architect.
- Employ Color Kinetics Application Engineering Services.
- Get detailed wiring diagrams and additional support from <http://support.colorkinetics.com>.

## Installation considerations

When creating your installation plan, consider the following:

- Location of PDS-150e in relationship to lights. Each ColorBlast 6 comes with a 60-foot power/data cable. Therefore, the PDS-150e must be located within 60 feet of the supported fixtures.
- Location of fixture and method of mounting. ColorBlast 6 can be installed indoors or outdoors on a wall, ceiling, or floor. Junction boxes and mounting methods vary according to location.

## Installing ColorBlast 6

### Steps to a successful installation:

1. Record serial numbers and identify fixtures as you unpack them.
2. Address the fixtures.
3. Install the power/data supplies.
4. Install ColorBlast 6 fixtures.
5. Connect power and data.

## Record Serial Numbers

1. As you unpack the fixtures record the serial numbers.  
Each ColorBlast 6 has a unique serial number programmed at the time of manufacture.
2. Write the serial numbers onto a Mapping Grid or use a bar code scanner along with Color Kinetics Serial Addressing Software to record each serial number.  
Color Kinetics Serial Addressing Software and instruction are located at <http://support.colorkinetics.com>.
3. Using the Layout Plan, assign the fixture to a layout position in the installation.
4. Using a weatherproof label, identify the fixtures installation position based on the Layout Plan. Place the identifying label in an inconspicuous location noting the order or placement in the installation. This step not only minimizes installation mistakes, but aids in post-installation light shows programming.

## Addressing the Lights

**Important:** Before you begin the installation, consider the scope of your lighting application and installation. Your ColorBlast 6 is set to light number one at the factory. If your application requires other addresses, you must set all light numbers before installing ColorBlast 6.

Set each serial number with a DMX address using one of the following methods.

**ZAPI:** Use Color Kinetics Zapi to set the DMX address for each fixture. Refer to the Zapi User Guide for step-by-step addressing instructions.

**SAS:** Use a PC with iPlayer 2, or a PC with Smart Jack 3 to address the fixtures. Download the Serial Addressing Software (SAS) and instructions from <http://support.colorkinetics.com>.

## Setting Individual Addresses:

1. With power disconnected, connect up to six ColorBlast 6 fixtures to the PDS-150e.
2. Attach the DMX interface (Zapi, iPlayer 2, or Smart Jack 3) to the DMX IN port on the PDS-150e.
3. Connect power to the PDS-150e.
4. Use Zapi or Serial Addressing Software to set the light address.
5. Disconnect power and then disconnect the addressed ColorBlast 6 fixtures.
6. Repeat steps 1 through 5 for each fixture.
7. After all fixtures are addressed, disconnect the DMX interface.

**NOTE:** Serial addressing gives you the option of addressing multiple fixtures through a single power supply or multiple power supplies. Refer to the Zapi User Guide or SAS Instruction Guide for details.

## Setting the Same Address to Multiple Lights:

1. With power disconnected, connect up to six ColorBlast 6 fixtures to the PDS-150e (one per terminal block).
  2. Attach the DMX interface, Zapi, to the DMX IN port on the PDS-150e.
  3. Connect power to the PDS-150e.
  4. Use Zapi to set the light number. All ColorBlast 6 fixtures connected to the PDS-150e are addressed to the same light number simultaneously.
- NOTE:** If you are using Serial Addressing Software, you must address the fixtures individually.
5. Disconnect the DMX interface.

**NOTE:** For applications using multiple, daisy chained power supplies, you can address all lights in the chain by attaching Zapi to the first power supply in the series.

## Install the PDS-150e Power/Data Supply

Following the Layout Plan, install the PDS-150e power/data supplies according to state and local codes. Refer to the PDS-150e Installation Guide for complete instructions.

Things to remember:

- Consult an Electrical Inspector to approve all wiring plans.
- PDS-150e must be located within 60-feet of the ColorBlast 6 fixtures.

**WARNING:** Ensure that the power supply is off before wiring or connecting fixtures to the PDS-150e. Failure to do so can result in serious injuries or death.

**CAUTION:** Never lengthen the ColorBlast 6 cable. Doing so will result in property damage and void warranty.

## Assemble ColorBlast 6

ColorBlast 6 can be installed indoors or outdoors; on walls, ceilings, or floors; with or without the canopy. With exception to floor mount without canopy, ColorBlast 6 requires some assembly. Refer to Fig. 2

1. Separate the lock nut from the grommet assembly.
2. Insert the grommet through base, or base and canopy when canopy is used. Installation environment determines use of canopy.
3. Attach the lock nut below base/canopy and tighten to 33.2 lb-in (3.75 N-m).
4. Insert cable through dome nut. (Loosen dome nut if necessary.)
5. Using a wrench, tighten the dome nut to create a water-tight seal. Tighten until the gap between the dome nut and fixed nut is 3/32-inch. Use the provided Allen wrench as gap gauge, measuring on the flats.

Fig. 2

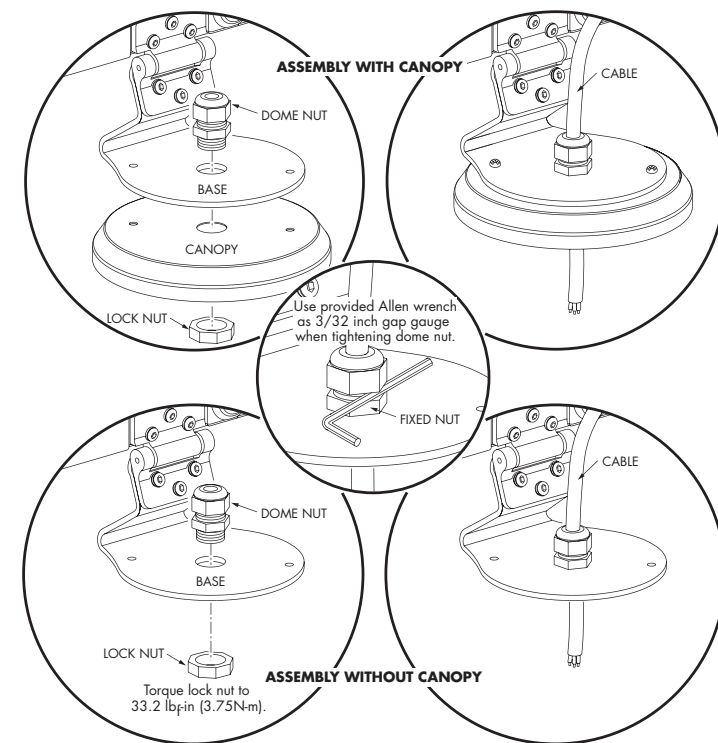

## Install ColorBlast 6

This fixture shall be installed by a qualified electrician in accordance with NEC and relevant local codes for Class 2 power sources.

ColorBlast 6 can be installed indoors or outdoors. When mounting on walls and ceilings, use an electrical junction box rated for your application.

**WARNING:** Power must be off before installing the ColorBlast 6.

### Indoor: Wall or Ceiling Mount

1. Attach the flat legs of the swivel bracket to the electrical junction box using the screws supplied with the junction box (See Fig. 3)
2. Insert the two fastening screws included with the ColorBlast 6 through the holes in the base and canopy assembly, and then through the holes in the bent leg of the swivel bracket.
3. Rotate the light fixture to the desired position, then tighten the screws to secure in place.

### Indoor: Floor Mount

When the light is used on a floor or other flat surface, you have the option of using it with or without the canopy.

- **With canopy:** In order for the canopy to sit level, the cable must not pass through the base plate and canopy. Assemble the fixture following Steps 1 through 3 of *Assembling ColorBlast 6*.
- **Without canopy:** The ColorBlast 6 comes ready to mount to a flat surface. No assembly is required. Do not pull cord through base plate.

Fig. 3

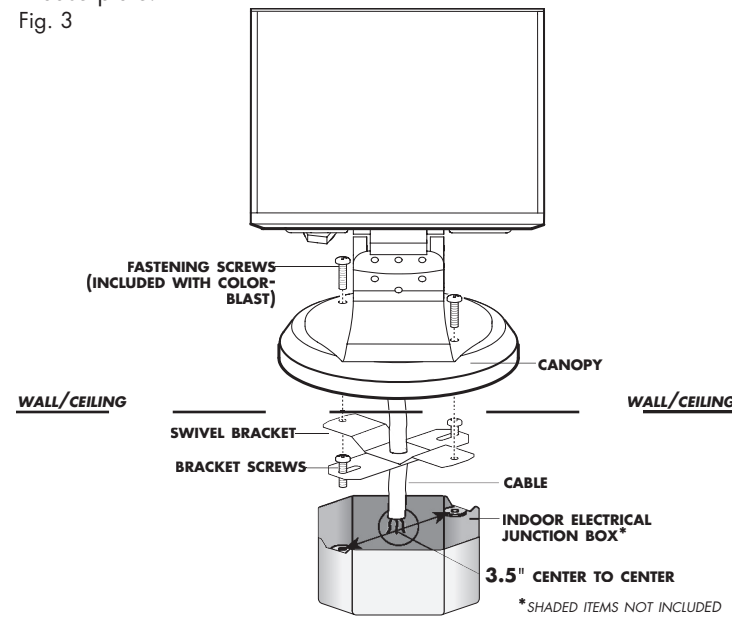

### Outdoor: Mount

When used outdoors, ColorBlast 6 must be mounted to a 4" electrical junction box rated for outdoor use.

1. To ensure a tight seal, do not use the canopy. Following the instruction in *Assembling ColorBlast 6*, attach the water-tight locking nut to the base plate, pull chord through, and tighten to seal.
2. Pull cable through junction box and conduit to PDS-150e.
3. Insert the outdoor mounting screws provided with the junction box through the ColorBlast 6 base plate, through the gasket, and then into the mounting holes on the junction box. Tighten the screws to hold the light in place. (See Fig. 4)

Fig. 4

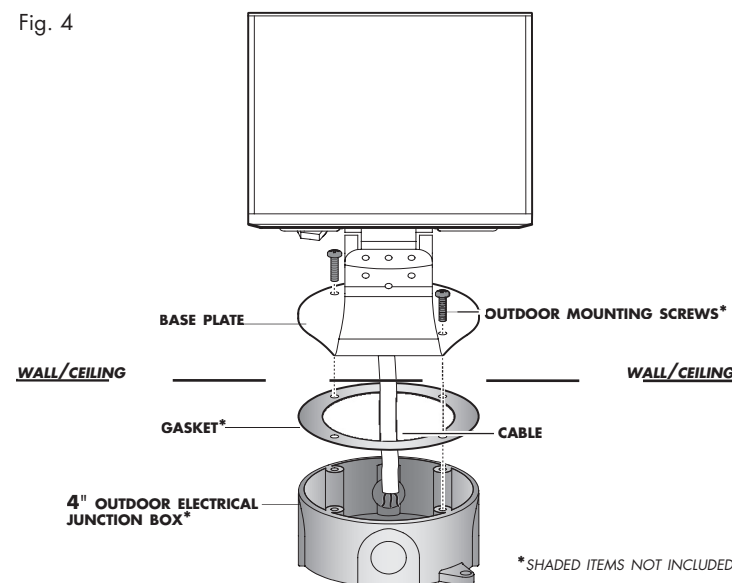

**NOTE:** Use the screws that come with the outdoor junction box. Do not use the screws that come with the ColorBlast 6.

## Electrical Connections

The ColorBlast 6 is compatible with Color Kinetics PDS-150e.

### Connecting Power

ColorBlast 6 requires 24 VDC. After installing the light fixtures, connect the power/data cable to the PDS-150e. Each PDS-150e supports six ColorBlast 6 fixtures. Wire one fixture per terminal block. (See Fig. 6)

**CAUTION:** Do not overload PDS-150e. Doing so will result in product failure and void the warranty.

**NOTE:** Each light must receive power directly from a power supply. You cannot daisy chain power from one ColorBlast 6 to another.

The ColorBlast 6 cable contains three color-coded wires:

- Black = Common
- White = Data
- Red = +24 VDC

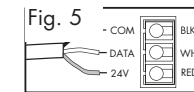

**CAUTION:** You must use the cable provided with the unit. Use of other cables may result in light failure and void the warranty.

Fig. 6

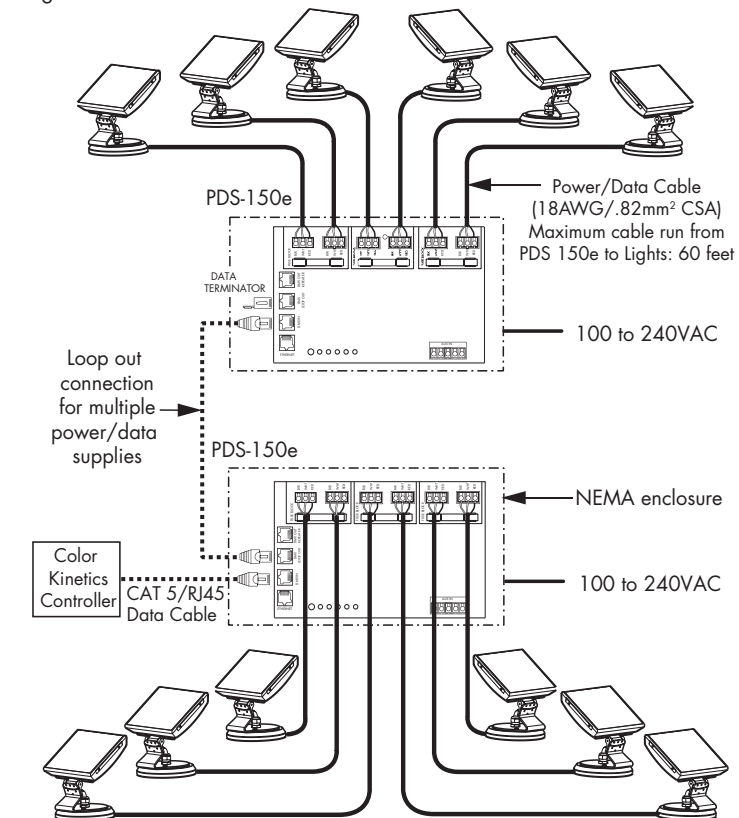

## Routine Maintenance

**Cleaning:** Using a soft cloth, clean surface with mild soap and water or window cleaner.

**Lubricating:** As needed, apply light household oil to the hinges.

## Important Information

### Strobe Warning

There is some anecdotal evidence that strobe lighting may induce epileptic symptoms in certain susceptible individuals, although no associated product warnings have been issued by United States government according to the Food and Drug Administration.

If strobe lights are used, some international regulatory agencies<sup>1</sup> recommend keeping flicker rates at or below four flashes per second (as less of the flicker-sensitive population will then be at risk of an attack). This flicker rate applies only to the overall output of any group of lights in direct view. However, when more than one strobe light is used, the flashes should be synchronized. End users should also consider issuing a warning, alerting audience or viewers to the presence of strobe lighting.

### Temperature Monitoring

For protection from extreme temperatures, the ColorBlast 6 has been designed with a temperature monitoring feature. If operating temperatures rise to an unsafe level, a compensation circuit is triggered and the ColorBlast 6 operation is interrupted causing the lights to turn dull red. After 30 minutes the lights will auto-cycle and return to full intensity.

To prevent additional power shut-downs, determine the cause of the overheating and correct the problem.

If any problems occur during usage, unplug the product immediately and call or email:

Color Kinetics Technical Support Group:  
1-888-FULL RGB or 617-423-9999 or  
support@colorkinetics.com

## ColorBlast 6 Specifications

<b>COLOR RANGE</b>	16.7 million (24bit) additive RGB colors Continuously variable intensity output range
<b>SOURCE</b>	High intensity power LEDs
<b>BEAM ANGLE</b>	24° beam angle
<b>DATA INTERFACE</b>	Color Kinetics full line of controller products
<b>FINISH</b>	Black, white, or aluminum powder coated die cast aluminum housing
<b>CONNECTORS</b>	Unified power and data cable
<b>LISTINGS</b>	UL, CE, and IP66
<b>POWER REQUIREMENT</b>	25W

### SOURCE LIFE

Color Kinetics illumination products utilize high brightness LEDs as the illumination source. LED manufacturers predict LED life of up to 100,000 hours MTBF (mean time between failure), the standard used by conventional lamp manufacturers to measure source life. However, like all light sources, LEDs also experience lumen depreciation over time. So while LEDs can emit light for an extremely long period of time, MTBF is not the only consideration in determining useful life. LED lumen depreciation is affected by numerous environmental conditions such as ambient temperature, humidity and ventilation. Lumen depreciation is also affected by means of control, thermal management, current levels, and a host of other electrical design considerations.

Color Kinetics systems are expertly engineered to optimize LED life when used under normal operating conditions [ambient temperature: -4°F to 104°F (-20°C to 40°C), humidity: 0-95% non-condensing humidity, adequate ventilation and air volume] and when operated using typical color-changing effects. Long-term operation outside of these ranges or conditions, or at the upper limits of these ranges or conditions, may subject the product to further degradation of the LED source life, or in extreme cases, failure of internal components. Source life information is based on LED manufacturers' data, as well as other third party testing.

### U.S. AND FOREIGN PATENTS AND PATENTS PENDING

Color Kinetics Incorporated grants the purchaser of its lighting products and controllers a personal and non-transferable license to use Chromacore®, its patented technology for networkable control of LED-based color changing lighting fixtures for illumination, display and design. This license is granted only by Color Kinetics Incorporated, and may not be transferred except by the grantor. The design, duplication, manufacture, or sale of other products using networkable control of LED-based color changing lighting may be prohibited and is not licensed hereunder. Other patents pending.

<sup>1</sup> Guide to Health, Safety and Welfare at Pop Concerts and Similar Events, HMSO Publications (UK)