



iCOLOR MR g2

POWERED BY CHROMACORE®



Color Kinetics® iColor® MR g2 is an intelligent, color changing lamp that delivers intense, saturated color and color changing effects. The stylish, silver housing fits into most standard MR16 fixtures, such as tracks, cables, rails, and pendants, and facilitates both new and retrofit installations. High-power LEDs, with a wide 60° beam angle and a narrow 24° beam angle, make iColor MR g2 suitable for a wide-range of applications and environments, including, architectural, theatrical, and retail environments where custom effects and saturated bursts of color are required. iColor MR g2 comes with an interchangeable frosted lens, and an accessory/adaptor ring (Item# 101-000050-00) is available for attaching lighting accessories and to ensure a proper fixture fit.

iColor MR g2 receives power and data via Color Kinetics PDS-70mr 24V with Smartjuice® technology. Smartjuice multiplexes incoming power and data onto an outgoing two-wire circuit for use with conventional MR16 fixtures and sockets. Fourteen MR g2 lamps can be powered by one PDS-70mr 24V, which is available with DMX, Ethernet, or preprogrammed data controls, and can be controlled by Color Kinetics full line of controllers, including Color Kinetics Light System Manager, or a third-party DMX controller.

Each iColor MR g2 comes pre-addressed to light number one. Using a DMX controller, simple effects, such as fixed color and color wash, require no additional addressing. Chasing effects across multiple lights, including Chasing Rainbow or Color Sweep, require further addressing using one of the following Color Kinetics addressing tools: Serial Addressing Software (SAS) or Zapi 1.5. For large installations, Light System Manager simplifies installations by discovering and addressing lights in a network.

iCOLOR MR G2 SPECIFICATIONS

COLOR RANGE	16.7 million (24-bit) additive RGB colors; continuously variable intensity output range
SOURCE	High power colored LEDs
BEAM ANGLE	24° narrow angle, 60° wide angle
HOUSING	Painted silver, die cast zinc, 2" (5 cm) diameter
CONNECTORS	Standard MR16 pins
LISTINGS	UL/cUL, CE

ENVIRONMENTAL SPECIFICATIONS

TEMPERATURE RANGE	Ambient: - 4°F to 104°F (- 20°C to 40°C); Surface: 167°F (75°C)
HUMIDITY RANGE	0 to 95% non-condensing humidity

COMMUNICATION SPECIFICATIONS

DATA INTERFACE	Color Kinetics data interface system
CONTROL	Color Kinetics three-channel RGB controllers, including Light System Manager Ethernet protocol, or third-party DMX512

ELECTRICAL SPECIFICATIONS

POWER REQUIREMENT	24VDC
POWER CONSUMPTION	Maximum: 5 Watt
POWER/DATA	Color Kinetics PDS-70mr 24V power/data supply

LED SOURCE LIFE

In traditional lamp sources, lifetime is defined as the point at which 50% of the lamps fail. This is also termed Mean Time Between Failure [MTBF]. LEDs are semiconductor devices and have a much longer MTBF than conventional sources. However, MTBF is not the only consideration in determining useful life. Color Kinetics uses the concept of useful light output for rating source lifetimes. Like traditional sources, LED output degrades over time (lumen depreciation) and this is the metric for SSL lifetime.

LED lumen depreciation is affected by numerous environmental conditions such as ambient temperature, humidity, and ventilation. Lumen depreciation is also affected by means of control, thermal management, current levels, and a host of other electrical design considerations. Color Kinetics systems are expertly engineered to optimize LED life when used under normal operating conditions. Lumen depreciation information is based on LED manufacturers' source life data as well as other third party testing. Low temperatures and controlled effects have a beneficial effect on lumen depreciation. Overall system lifetime could vary substantially based on usage and the environment in which the system is installed.

Temperature and effects will affect lifetime. Color Kinetics rates product lifetime using lumen depreciation to 50% of original light output. When the fixture is running at room temperature using a color wash effect, the range of lifetime is in the range of 80,000-100,000 hours. This is LED manufacturers' test data. High output is defined as any LED device that is 1/2 watt or above. For more detailed information on source life, please see www.colorkinetics.com/ lifetime.

CHROMACORE®
BY COLOR KINETICS

OPTIBIN®
BY COLOR KINETICS

SMARTJUICE®
BY COLOR KINETICS



ITEM# 101-000049-02 (Wide Angle)
ITEM# 101-000049-06 (Narrow Angle)

This product is protected by one or more of the following patents: U.S. Patent Nos. 6,016,038, 6,150,774 and other patents listed at <http://colorkinetics.com/patents/>. Other patents pending.

©2005-2006 Color Kinetics Incorporated. All rights reserved. Chromacore, Chromasic, Color Kinetics, the Color Kinetics logo, ColorBlast, ColorBlaze, ColorBurst, ColorCast, ColorPlay, ColorScape, Direct Light, iColor, iColor Cove, iPlayer, Optibin, Powercore, QuickPlay, Sauce, the Sauce logo, and Smartjuice are registered trademarks and DIMand, IntelliWhite, Video With Light, and Light Without Limits are trademarks of Color Kinetics Incorporated.

All other brand or product names are trademarks or registered trademarks of their respective owners.

BRO137 Rev 03

Specifications subject to change without notice. Refer to www.colorkinetics.com/ for the most recent data sheet versions.

iCOLOR MR g2 NARROW ANGLE

PHOTOMETRIC PERFORMANCE

Photometric data is based on test results from an independent testing lab.

SOURCE SPECIFICATIONS

Optics:	Metallized polycarbonate reflectors
Lens:	Tempered clear glass lens
Source:	10 LEDs (4 red, 3 green, 3 blue)
Beam Angle:	24° (at 50% of peak illuminance)
Distribution:	Symmetric direct illumination
CCT:	Adjustable 1,000–10,000K
CRI:	Not measurable (CIE 13.3-1995)

ILLUMINANCE DISTRIBUTION

0.3	1.3	1.4	2.3	1.3	0.3	1.5'/0.5m
3.2	14.0	15.1	24.8	14.0	3.2	
1.3	3.2	5.2	5.2	3.2	1.3	0'/0m
14.0	34.4	56.0	56.0	34.4	14.0	
2.3	5.2	9.1	8.1	5.3	2.3	0'/0m
24.8	56.0	98.0	87.2	57.0	24.8	
1.4	5.3	8.2	9.1	5.3	1.4	0'/0m
15.1	57.0	88.3	98.0	57.0	15.1	
1.3	3.3	5.4	5.4	3.3	1.3	1.5'/0.5m
14.0	35.5	58.1	58.1	35.5	14.0	
0.3	1.3	1.4	2.4	1.3	0.3	1.5'/0.5m
3.2	14.0	15.1	25.8	14.0	3.2	

CANDLE POWER DISTRIBUTION

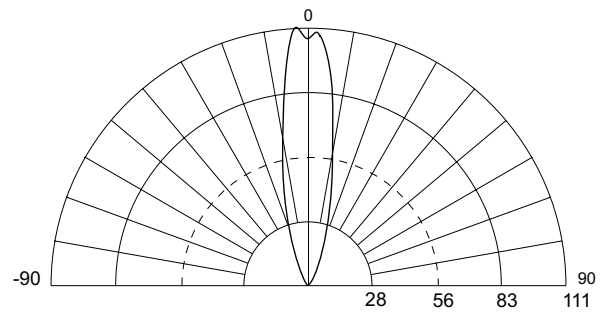

Measured on: White
 Beam center: 111 cd
 Multipliers: 0.34 Red, 0.47 Green, 0.21 Blue
 Dashed line: Indicates 50% of peak

ILLUMINANCE DISTRIBUTION PARAMETERS

Units: Footcandles (top)/Lux (bottom)
 10.8 lux = 1 fc
 Location: Bottom of grid, 1'/0.3m from surface, light at perpendicular to surface
 Measured on: All, reflectance model 50%

ILLUMINANCE

DISTANCE	1'	2'	3'	4'
	0.3m	0.6m	1.0m	1.2m
WHITE	107.0 1151.7	26.6 286.3	11.8 127.0	6.6 71.0
RED	36.4 391.6	9.0 97.3	4.0 43.2	2.2 24.2
GREEN	49.8 585.6	12.4 133.1	5.5 59.1	3.1 33.0
BLUE	22.4 240.7	5.6 59.8	2.5 26.5	1.4 14.8

Measured in: Footcandles (top)/Lux (bottom) on axis.
 Measured on: All, reflectance 0%

LIGHT OUTPUT

	TOTAL OUTPUT (lumens)	POWER (Watts)	EFFICACY (lm/W)
WHITE	28	4.0	7.0
RED	9.5	1.3	7.3
GREEN	13.0	1.3	10.0
BLUE	5.9	1.3	4.5

iCOLOR MR g2 WIDE ANGLE

PHOTOMETRIC PERFORMANCE

Photometric data is based on test results from an independent testing lab.

SOURCE SPECIFICATIONS

Optics:	Metallized polycarbonate reflectors
Lens:	Tempered clear glass lens
Source:	10 LEDs (4 red, 3 green, 3 blue)
Beam Angle:	60° (at 50% of peak illuminance)
Distribution:	Symmetric direct illumination
CCT:	Adjustable 1,000–10,000K
CRI:	Not measurable (CIE 13.3-1995)

ILLUMINANCE DISTRIBUTION

0.4 4.3	0.5 5.4	0.7 7.5	0.9 9.7	0.6 6.5	0.4 4.3	1.0'/0.3m
0.6 6.5	1.0 10.8	1.2 12.9	1.1 11.8	0.9 9.7	0.6 6.5	
0.9 9.7	1.2 12.9	1.7 18.3	1.6 17.2	1.1 11.8	0.9 9.7	0'/0m
0.7 7.5	1.1 11.8	1.6 17.2	1.7 18.3	1.2 12.9	0.7 7.5	
0.5 5.4	0.9 9.7	1.1 11.8	1.2 12.9	1.0 10.8	0.5 5.4	
0.4 4.3	0.5 5.4	0.7 7.5	0.9 9.7	0.6 6.5	0.4 4.3	1.0'/0.3m
1.0'/0.3m	0'/0m	0'/0m	0'/0m	0'/0m	1.0'/0.3m	

CANDLE POWER DISTRIBUTION

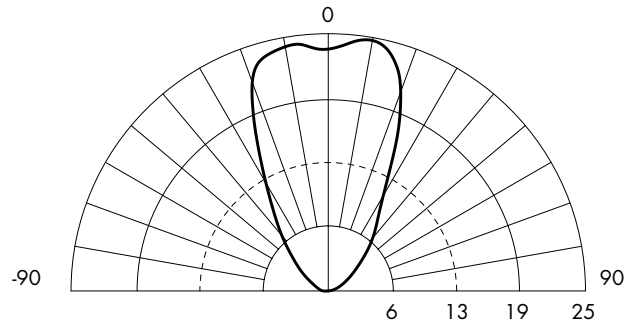

Measured on: White
 Beam center: 25 cd
 Multipliers: 0.40 Red, 0.18 Green, 0.42 Blue
 Dashed lined: Indicates 50% of peak

ILLUMINANCE DISTRIBUTION PARAMETERS

Units: Footcandles (top)/Lux (bottom)
 Location: 1'/0.3m from, and perpendicular to surface
 Multipliers: 0.40 Red, 0.18 Green, 0.42 Blue
 Measured on white, reflectance model: 50%

ILLUMINANCE

DISTANCE	1' 0.3m	2' 0.6m	3' 1.0m	4' 1.2m
WHITE	40.2 432.7	6.8 73.2	2.7 29.1	1.4 15.1
RED	16.1 173.1	2.7 29.3	1.1 11.6	0.6 6.0
GREEN	7.2 77.9	1.2 13.2	0.5 5.2	0.3 2.7
BLUE	16.9 181.7	2.9 30.7	1.1 12.2	0.6 6.3

Measured in Footcandles (top)/Lux (bottom) on axis.
 Measured on white, reflectance 0%

LIGHT OUTPUT

	TOTAL OUTPUT (lumens)	POWER (Watts)	EFFICACY (lm/W)
WHITE	29	4.0	7.3
RED	11.6	1.3	9.3
GREEN	5.2	1.3	4.2
BLUE	12.2	1.3	9.7

iCOLOR MR g2

PHYSICAL DIMENSIONS

